

# P2H

## PRECISION STRAIGHTSIDE PRESSES

560 - 1,424 kN

630 - 1,600 Metric Tons Capacity



## PRODUCT OVERVIEW

P2H presses are designed for universal stamping applications. The flexibility of an available adjustable stroke, and quick access slide, with motorized shutheight adjustment, expand the use of the machine from flat blanking to multiple forming or drawing operations. The rigid guiding system, combined with hydraulic overload and hydraulic clutch and fast braking provide the ultimate in part precision, die life and productivity.

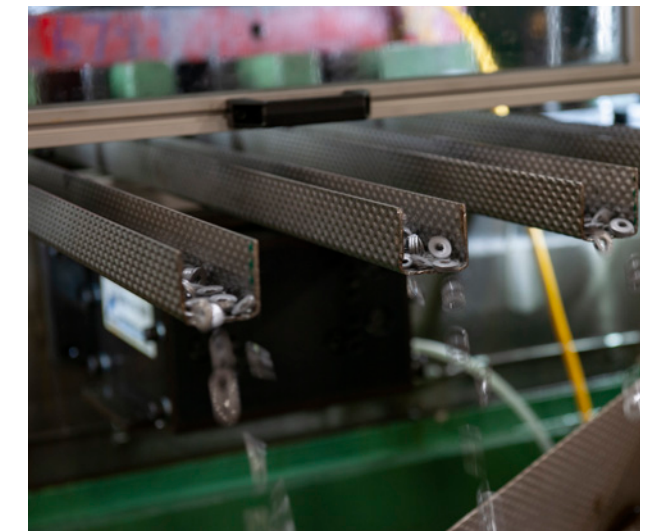
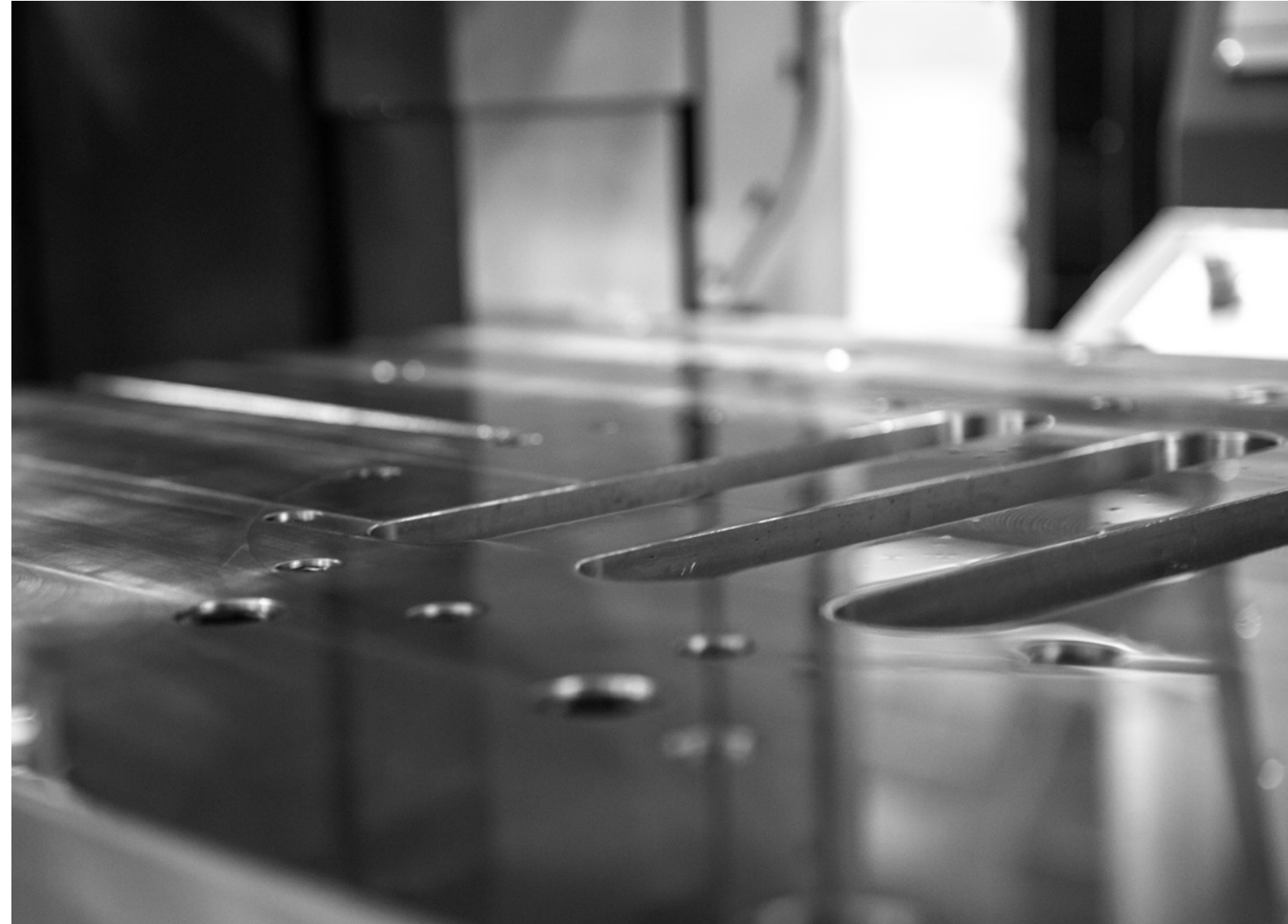

- 1** The P2H cast iron frame, forged high strength, alloy steel drive train rated to full press tonnage and 50% reverse loading, reduces overall press vibration levels.
- 2** The quick lift slide feature facilitates die inspection, material threading and misfeed troubleshooting, contributing to overall production efficiency.
- 3** The drive system bearing design promotes prolonged machine accuracy and die life.
- 4** All main and connection bearings have full film lubrication with pressurized oil supplied to each bearing within the crankshaft. The consistent oil film gives the ultimate dynamic bearing stiffness and longevity.



# STANDARD FEATURES

## Cast Iron Frame

The cast iron frame of the P2H has increased mass to better dampen the overall press vibration level. Operator controls are conveniently flush mounted in the upright design. The open top of the frame provides easy access for routine maintenance.

**One-piece frame on P2H-63 & P2H-100**  
**Four-piece frame on P2H-160**

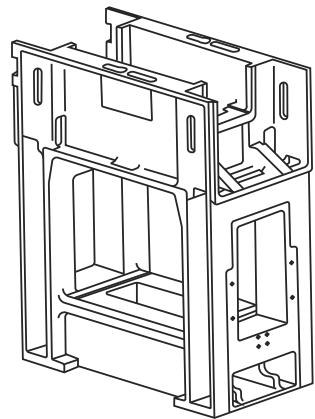

## Combination Hydraulic Flex Disc Clutch and Brake

Includes dual clutch valves providing quick starts and faster stopping times for high production speeds.



## Air Operated Flywheel Brake

Electrically interlocked with "stop" circuit eliminates "coasting" resulting in quicker access to die area.

## Quick Lift Slide

Quick access to dies is provided by a hydraulic system which lifts the slide to a fixed open position. The hydraulic system returns the slide to the original shutheight position against a mechanical stop, maintaining accurate tool settings. This feature facilitates die inspection, material threading and misfeed troubleshooting, contributing to overall production efficiency.

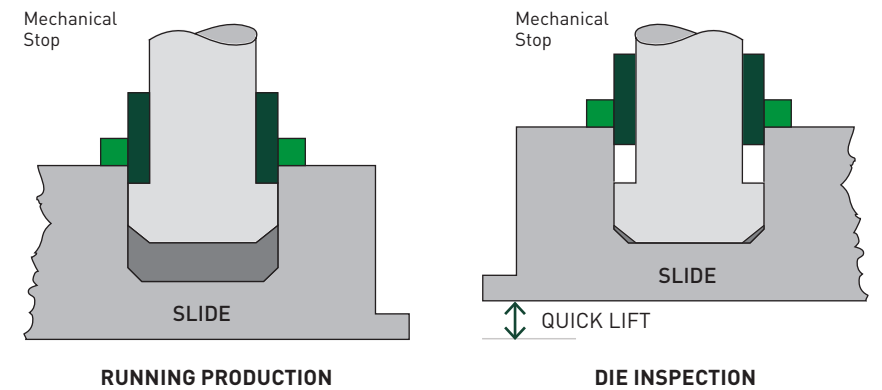

## Hydraulic Slide Lockup

Eliminates clearance in slide adjustment parts to reduce the effects of snap-through forces and punch penetration, thus reducing vibration.

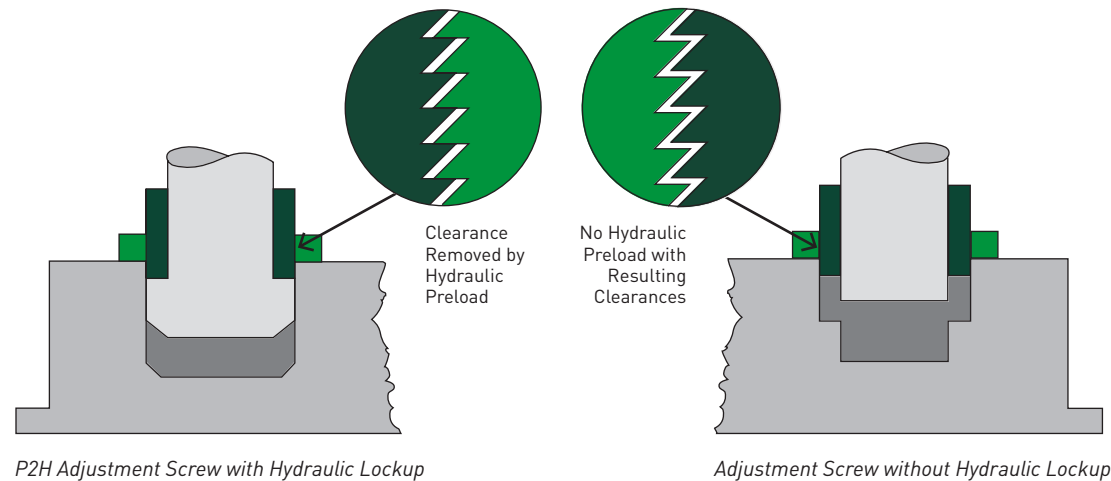

## Hydrostatic Piston Drive

The P2H drive includes two large diameter hydrostatically guided pistons. Large wrist pins and connection bushings are lubricated through the crankshaft with pressurized oil, increasing tensile stiffness and providing the ultimate in bottom-dead-center repeatability. The drive system bearing design promotes prolonged machine accuracy and die life.



## Monitored Lubrication

All main and connection bearings have full film lubrication with pressurized oil supplied to each bearing within the crankshaft. The system is designed to stop the press in the event of an interruption of the oil flow. The consistent oil film gives the ultimate dynamic bearing stiffness and longevity resulting in better bottom-dead-center repeatability and die life.

## Slide Guiding

The P2H guiding system assures positive centering of the slide and resistance to off-center loads. The slide is piston driven and guided by sixteen hydrostatic centering pads plus four hydrodynamic guide posts which are at material pass line level. Punch to die clearance is maintained and die life is extended.

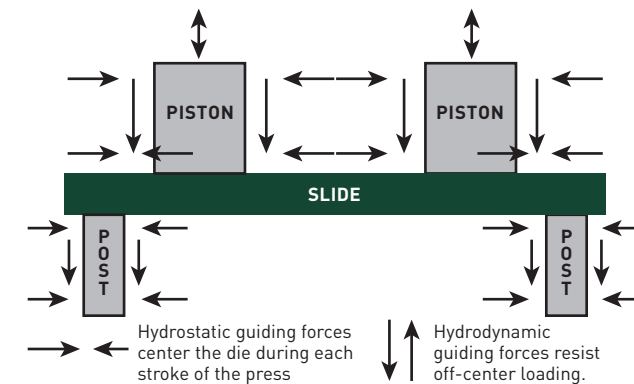

## STANDARD FEATURES

### Motorized Shutheight Adjustment

The motorized shutheight adjustment with digital readout eases and speeds the die setting procedure, contributing to longer production time and better part production as a result of accurate repeatable die settings.

### Main Drive Motor

The P2H variable frequency main drive motor is totally enclosed, fan-cooled, variable speed and provides proven durability and increased torque response.

### Integral Press Shock Mounts

Standard press mounts are designed as an integral part of the frame and serve as levelers in addition to vibration absorbers. Mount adjustment screws with fine threads reduce adjustment torque. Covers protect the screws from debris which could gall the threads.

### Production Management Control (PMC)

Incorporates all press functions including:

- Full machine diagnostics detailing all press and feed line faults
- Multiple selectable languages
- Open architecture which allows for greater convenience in planning and maintenance.
- PLC and color touch screen technology; all press and feed line functions can be monitored for efficient diagnosis of production line faults

Available popular options include: die protection, load monitoring as well as automatic shutheight controls.



### FieldHawk - Industry 4.0

FieldHawk is a cloud-based communications mobile application designed to communicate with your NP&A stamping press lines from your IOS or Android mobile devices. Cloud-based, secured communications allows all authorized users to check machinery status from anywhere you can get phone service and/or an internet connect, reducing downtime.



### Mirco-Speed Barring

The P2H is available with micro-speed barring that allows for easier die set-up.

## OPTIONAL FEATURES

### Infinitely Adjustable Stroke

Provides more flexibility and higher production capability:

- No limit on stroke length within the range
- Quick and simple pushbutton adjustment
- Dial-in, or pushbutton stroke length via die number automatically sets stroke & shutheight for easy changeover
- Provides micro-speed barring feature and allows for easier die set-up
- Extremely accurate bottom-dead-center repeatability and parallelism

#### *Benefits Include:*

#### **Short Stroke for Flat Blanking Operations:**

- Higher production speeds for blanking dies
- Reduced vibration and noise
- Reduced punch impact velocity
- Die guide pins can remain in bushings

#### **Long Stroke for Forming & Drawing Operations:**

- Increased forming range.
- Longer feed cycle
- Optimized press stroke for draw applications
- Increased access for die maintenance

### High Speed Drives

The P2H is available with high speed drives for increased part productivity. Refer to the specifications on page 8 for availability and speeds.

### Die Area Doors

The P2H frame is designed to accept an integral lift-type enclosure which is both mechanically and electrically interlocked.

### High Energy Drive

Available on the P2H-100 and P2H-160, an auxiliary flywheel doubles the available energy and produces a higher rating off the bottom of the stroke.

### Die Rollers & Die Clamping

Minster P2H presses are easily equipped with die rollers and clamping to speed up die changing and further enhance press uptime and productivity. Consult Nidec Minster for answers to your quick-die-change requirements.

### Hydraulic Overload Protection

The hydraulic overload valve is attached directly to the slide and is pressure activated immediately relieving the overload. In addition, a switch initializes the stop circuit to help protect expensive dies.

### Shutheight Thermal Stabilization System

For more stringent applications which require extremely tight shutheight control, a Shutheight Thermal Stabilization System is available. This unique feature is integrated into the press lubrication and hydraulic system.

## OPTIONAL FEATURES

### Single-Geared Twin Drive Arrangement

Available on the P2H-160, this arrangement is designed for slower speed and/or higher energy applications. In this arrangement, Minster's hydraulic clutch and brake unit is mounted on the drive shaft on top of the crown. This drives the eccentric shaft from both ends through opposed helical gears, promoting die parallelism, even in off-center loading conditions. The geared version of the P2H is available with longer stroke lengths than the flywheel version, and is equipped with air counterbalance cylinders.



### One Brand: A World of Resources

Nidec Press & Automation is the full service pressroom provider of choice for businesses in more than 90 countries and on six continents. Comprised of leading press room product brands, we ensure a complete offering of machinery, services and technology to meet your exact needs, enabling you to rely on one source.

Discover the freedom to achieve, to maximize and to drive your operation to exceed your goals. At Nidec Press & Automation, your success is the core of our focus and how we design our solutions to meet the rigid needs of the metal forming industry.

Choosing to work with us means you gain a constant resource with a global footprint, the brightest minds behind our solutions, and backed by regionally based OEM support ready to work as a natural extension of your team.

**Our promise to you is simple:  
We're with you whenever and wherever  
business takes you.**



#### MACHINERY

- Turn Key Systems
- Individual Components
- System/Tech Upgrades
- Industry 4.0 Software Upgrades
- Integrated Controls

#### METAL FORMING PRESS APPLICATIONS

- Mechanical
- Servo
- Transfer
- High-Speed & Electrical
- Electrical Vehicle (EV)
- Lamination
- Container Cupping
- Container End-Conversion
- Container Shell
- Gap/D-Frame

#### AUTOMATION

- Press Tending / Robotics
- Integrated Transfers
- High Speed Servo Feeds
- High Speed Gripper Feeds
- Heavy-Duty Coil Lines

#### GLOBAL SERVICE NETWORK

- Field Service
- Remanufacturing
- Spare Parts
- Technical Service
- Training
- Planned Maintenance
- Inspection & Audit
- Relocation
- Upgrade Services
- Engineering Services







## One Brand: A World of Resources

---

A single source solution that will help you find the efficiencies you want — all from the products, services and technology of Nidec Press & Automation.

[nidecpa.com](http://nidecpa.com)